

THE INFORMATION CONTAINED HEREIN IS CONSIDERED "PROPRIETARY" TO BEL FUSE INC. AND SHALL NOT BE COPIED, REPRODUCED OR DISCLOSED WITHOUT THE WRITTEN APPROVAL OF BEL FUSE INC.

LED1 POLARITY			LED2 POLARITY		
PIN 7	PIN 8	COLOR	PIN 9	PIN 10	COLOR
-	+	YELLOW	+	-	ORANGE
/	/	/	-	+	GREEN

PRELIMINARY



ELECTRICAL CHARACTERISTICS @ 25°C

URNS RATIO

TX 1CT : 1
RX 1CT : 1

□CL @ 100kHz/100mVRMS 350μH MIN.
8mA DC BIAS (0°C - 70°C)

INS. LOSS
1MHz TO 100MHz -1.0 dB MAX

RET. LOSS (MIN) @ 100ΩHMS ±15%
1MHz-30MHz -18 dB
30MHz-60MHz -18+20LOG(F/30MHz) dB
60MHz-80MHz -12 dB

CROSS TALK (TX - RX)
500kHz-100MHz -35 dB MIN

CM TO CM REJ
100kHz-100MHz -30 dB MIN

CM TO DM REJ
100kHz-100MHz -40 dB MIN

OPERATING TEMPERATURE: -40 TO +85°C

HIPOT (Isolation Voltage): 1500 Vrms or 2250 VDC
100% OF PRODUCT TESTED IN PRODUCTION
TO COMPLY WITH IEEE 802.3 REQUIREMENTS

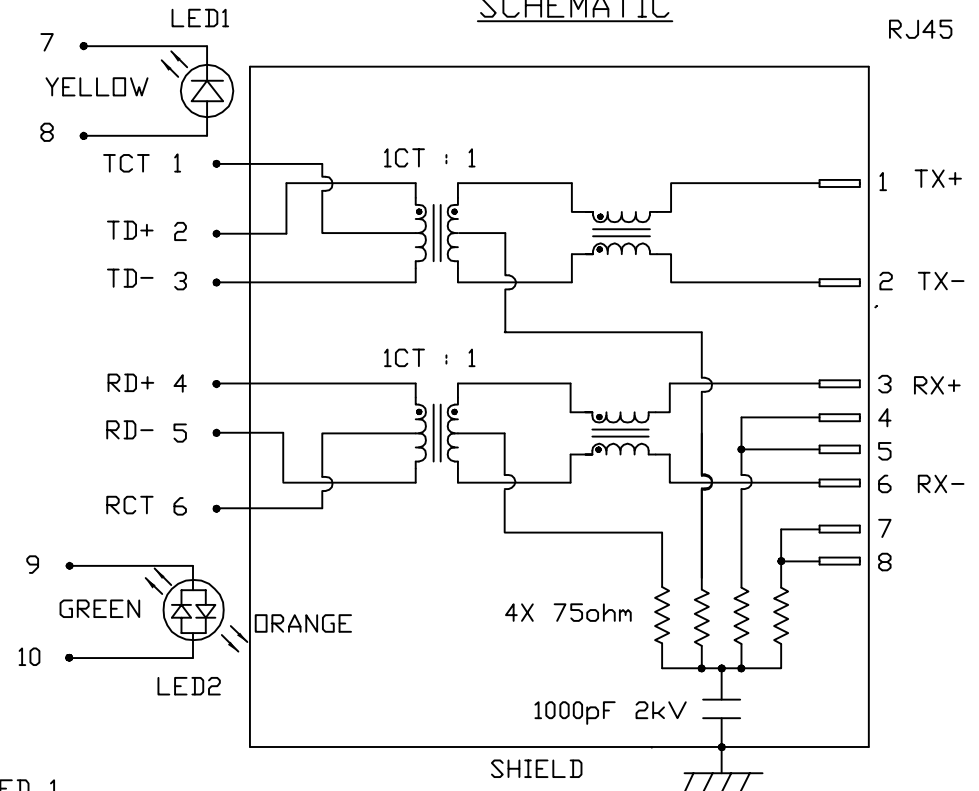

LED 1
VF (FORWARD VOLTAGE) IF=20mA YELLOW 2.1V TYP.
λD (DOMINANT WAVELENGTH) IF=20mA YELLOW 590nm TYP.
LED 2
VF (FORWARD VOLTAGE) IF=20mA ORANGE 2.0V TYP.
GREEN 2.2V TYP.
λD (DOMINANT WAVELENGTH) IF=20mA ORANGE 610nm TYP.
GREEN 565nm TYP.

DRWN	DATE	TITLE	PART NO. / DRAWING NO.	STANDARD DIM.		[] METRIC DIM. AS REFERENCE		bel
				TOL.	IN INCH	UNIT : INCH [mm]	REV. : X1	
DB	11-10-05	1X1 MagJack® FOR 10/100	08B0-1X1T-36-F	.X	/	SCALE : N/A	SIZE : A4	COMPONENTS FOR A CONNECTED PLANET
CHKD	DATE	(EXT. TEMP. RANGE)	FILE NAME	.XX	/	⊕	PAGE : 2	
SC	11-10-05		08B0-1X1T-36-F-X1.DWG	.XXX	/			

THE INFORMATION CONTAINED HEREIN IS CONSIDERED "PROPRIETARY" TO BEL FUSE INC. AND SHALL NOT BE COPIED, REPRODUCED OR DISCLOSED WITHOUT THE WRITTEN APPROVAL OF BEL FUSE INC.

MECHANICAL SPECIFICATION

PRELIMINARY

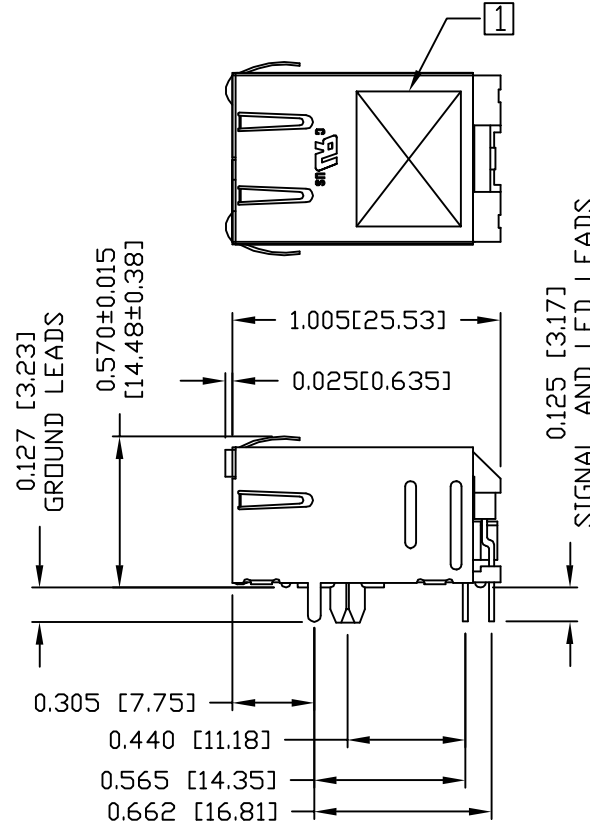
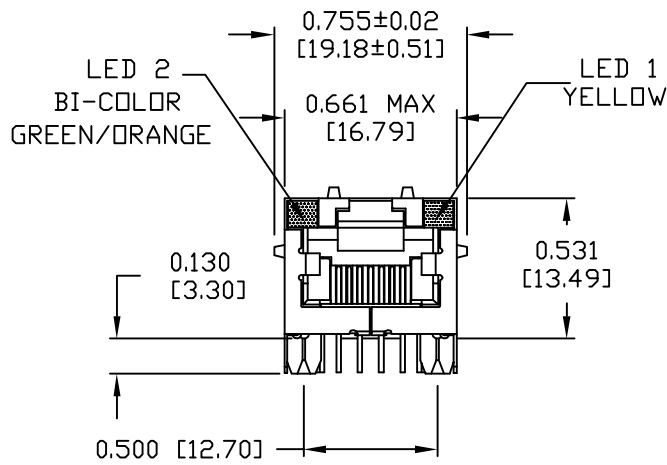

RECOMMENDED PCB FOOTPRINT COMPONENT SIDE VIEW

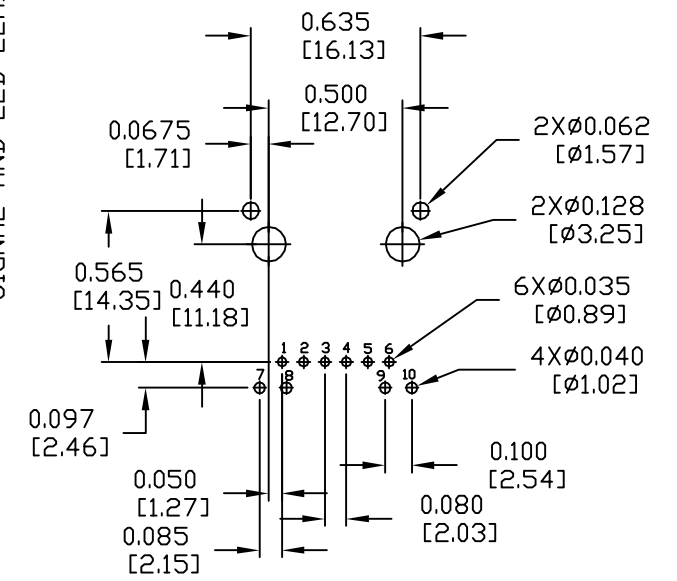

- NOTES:**
 PLASTIC HOUSING: THERMOPLASTIC PBT
 FLAMMABILITY RATING UL 94V-0
 CONTACTS PLATING: 50 MICRO-INCH HARD GOLD PLATING
 PINS: TIN-COATED COPPER WIRE, DIA 0.018 INCH.
 METAL SHIELD: NICKEL OR TIN PLATED ON COPPER ALLOY.
 (ALL NICKEL PLATED GROUND LEADS ARE SOLDER DIPPED)

1. MARK PART WITH MFG LOGO, MFG NAME, PART NUMBER, AND DATE CODE.

UL US UL RECOGNIZED - FILE #E196366 AND E169987.
 ROHS COMPLIANCE, PER EU DIRECTIVE 2002/95/EC

DRWN DB	DATE	TITLE 1X1 MagJack® FOR 10/100 (EXT. TEMP. RANGE)	PART NO. / DRAWING NO. 08B0-1X1T-36-F	STANDARD DIM. TOL. IN INCH		[] METRIC DIM. AS REFERENCE		 COMPONENTS FOR A CONNECTED PLANET
	DATE			UNIT : INCH [mm]	REV. : X1			
	CHKD SC			SCALE : N/A	SIZE : A4			
			FILE NAME 08B0-1X1T-36-F-X1.DWG	.X				
				.XX				
				.XXX	±0.010			PAGE : 3

THE INFORMATION CONTAINED HEREIN IS CONSIDERED "PROPRIETARY" TO BEL FUSE INC. AND SHALL NOT BE COPIED, REPRODUCED OR DISCLOSED WITHOUT THE WRITTEN APPROVAL OF BEL FUSE INC.

SUGGESTED PANEL OPENING

PRELIMINARY

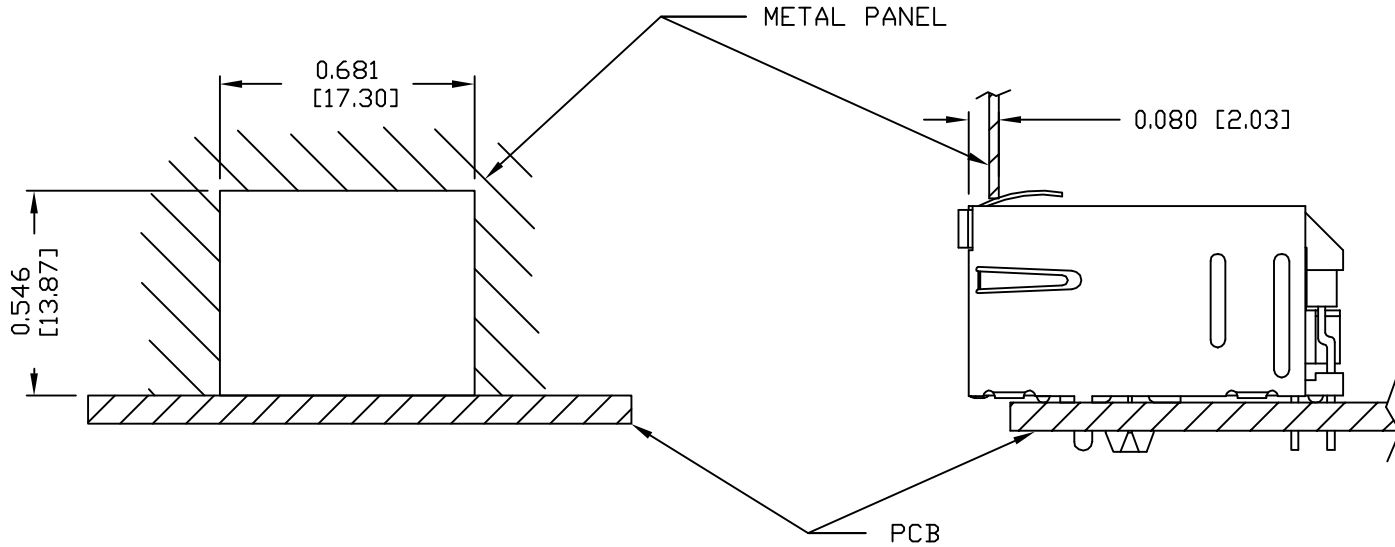

NOTE:

THE DISTANCE OF PANEL INSIDE SURFACE RELATIVE TO FRONT SURFACE OF PART IS ONLY A SUGGESTION. IN CASE THIS DISTANCE IS DIFFERENT, THE REQUIRED PANEL OPENING DIMENSIONS CHANGE ACCORDINGLY.

DRWN DB	DATE	TITLE 1X1 MagJack [®] FOR 10/100 (EXT. TEMP. RANGE)	PART NO. / DRAWING NO. 08B0-1X1T-36-F	STANDARD DIM.		[] METRIC DIM. AS REFERENCE		 COMPONENTS FOR A CONNECTED PLANET		
	CHKD SC			DATE 11-10-05	FILE NAME 08B0-1X1T-36-F-X1.DWG	TOL. IN INCH			UNIT : INCH [mm]	REV. : X1
						.X			SCALE : N/A	SIZE : A4
				.XX						
				.XXX	±0.005		PAGE : 4			